

# ADC-800 CAM



## HDV camera HD/SD A to D converter

Miranda's ADC-800 CAM is a compact, camera mounted interface which allows live HD digital monitoring and recording from an HDV camcorder. This is achieved by converting the EE uncompressed component analog output to HD-SDI, with left/right audio and Time Code embedded. This path overcomes the processing delay inherent with the MPEG-2 Long GOP structure, which makes it inappropriate to use the HDV stream for live monitoring. This process also avoids having to use many cables for recording. The ADC-800 CAM also provides separate on-screen display, including markers, Time Code burn-in, VU meters, and camera status.

### KEY FEATURES AND BENEFITS

- > HD/SD 10-bit component analog video to digital converter
- > Digital video output with audio and Time Code embedded
- > On-screen display provides Time Code burn-in, 4:3 aspect ratio markers, audio VU meters and camera status
- > Time Code can be extracted from LANC or LTC
- > Supported Formats:
  - SD 525/625
  - HD 72050, 59.94
  - HD 1080i 50, 59.94
- > Detail enhancer
- > Compact, camera mounted design
- > Wide power range of 6 V to 17 V

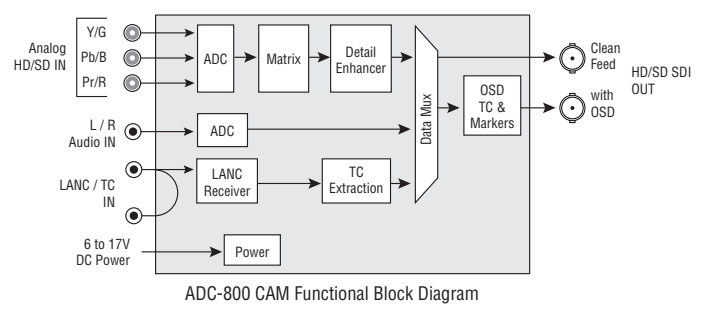

### TECHNICAL SPECIFICATIONS

Weight:	371 g	<b>ELECTRICAL</b>	
Processing delay:	141 μs maximum	Voltage range:	6-17 VDC
		Power:	5 W

### ORDERING INFORMATION

ADC-800 CAM                      HD/SD A to D converter w/audio and TC embedded

## Live HD recording and monitoring

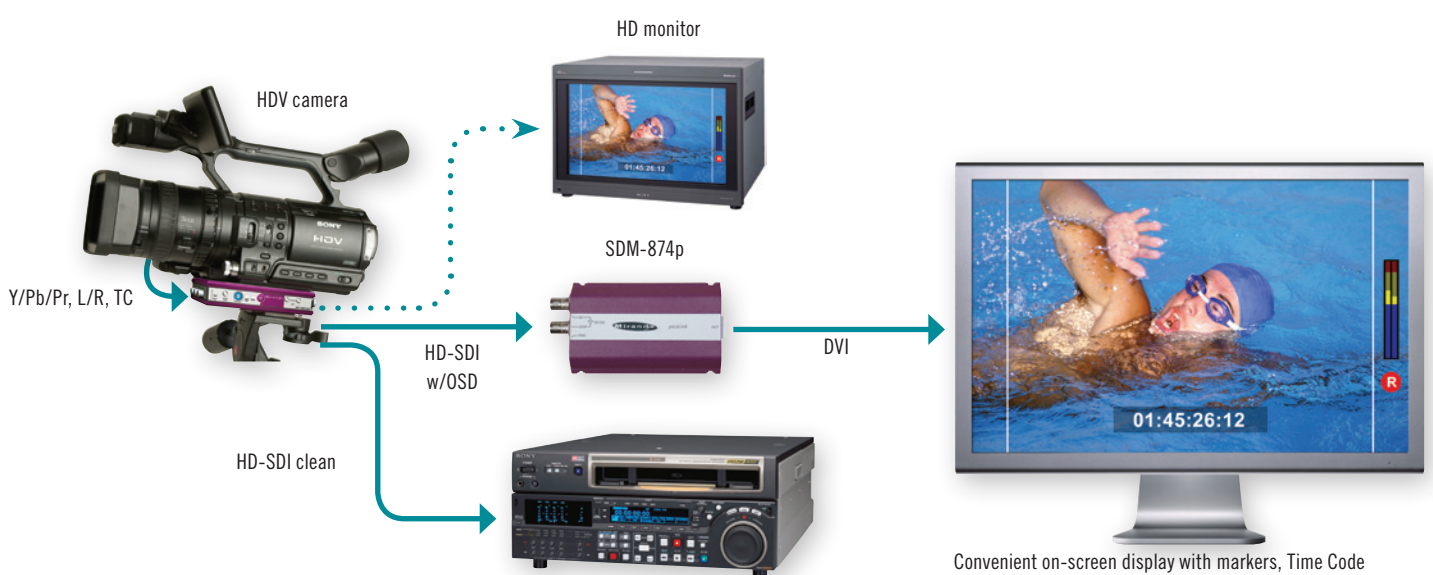

Convenient on-screen display with markers, Time Code burn-in, Peak Meters, and camera status (Sony, Canon).