

Vertigo XG

Advanced HD/SD graphics processor

The Vertigo XG processor is ideal for the most advanced, data-driven channel branding and promo graphics, including in-show promos and program junction promos. This single/dual channel graphics processor has the processing performance for dynamic and pre-rendered graphics. It provides multi-level character generation, animation/still and clip playout, as well as dual DVEs and audio mixing.



KEY FEATURES AND BENEFITS

Multi-level character generation

- › A powerful, HD/SD character generator allows the playout of virtually unlimited layers of animated and dynamically updated text
- › SD output as NTSC or PAL, HD output as 1080i, 720p or 480p
- › VANC + VBI extraction processing and insertion, or VAnc/VBI pass through

Clips, animations and stills

- › Storage for up to 400 hours of video/audio clips, with simultaneous playout of multiple clips
- › Playout of an almost unlimited number of layers of animated and still graphics for the most advanced branding and promotional effects
- › Integration with Vertigo Suite for productive graphics workflows

Strong data interfacing

- › When combined with the Vertigo Suite graphics automation, Vertigo XG offers the most advanced data-interfacing capabilities for even the most complex graphics, such as business news, sports results and elections.

Video switching plus voice-overs

- › Vertigo XG offers integral A/B video switching capabilities (single channel version), including cuts, fades and wipe transitions
- › Four group audio support (16 embedded channels) and up to 8 AES inputs
- › Audio supported at 16, 20 and 24-bit depths at 48 kHz

Effective automated & manual control

- › Full automation control is performed by serial, Ethernet and GPI automation commands. Manual control is offered by the Branding Panel and Xpanel GUI

Easy configuration and robust performance

- › Robust broadcast architecture with video bypass, redundant power, RAID storage, hot-swappable fans and drives
- › Embedded O/S
- › Easy configuration using web server

Streamlined workflow with Vertigo Suite

- › Full integration with the Vertigo Suite graphics automation for highly productive channel branding and promotional graphics workflows

Dual or single channel operation

- › Two versions are available for single or dual channel operation (with fully independent graphics capabilities on each output, making it ideal for dual-casting):
 - › Single channel (Vx-Vertigo-XG-21-e):
 - Dual program inputs
 - Single program output
 - Fully redundant PSUs (3)
 - Embedded audio processing plus up to 4 AES inputs/8 AES outputs
 - 1 TB RAID 1 storage (2 x 1TB mirrored), upgradable to 2TB
 - › Dual channel (Vx-Vertigo-XG-22-e):
 - Dual program inputs
 - Dual fill/key outputs
 - Fully redundant PSUs (3)
 - Embedded audio processing plus up to 8 AES inputs/16 AES outputs
 - 1 TB RAID 1 storage (2 x 1TB mirrored), upgradable to 2TB

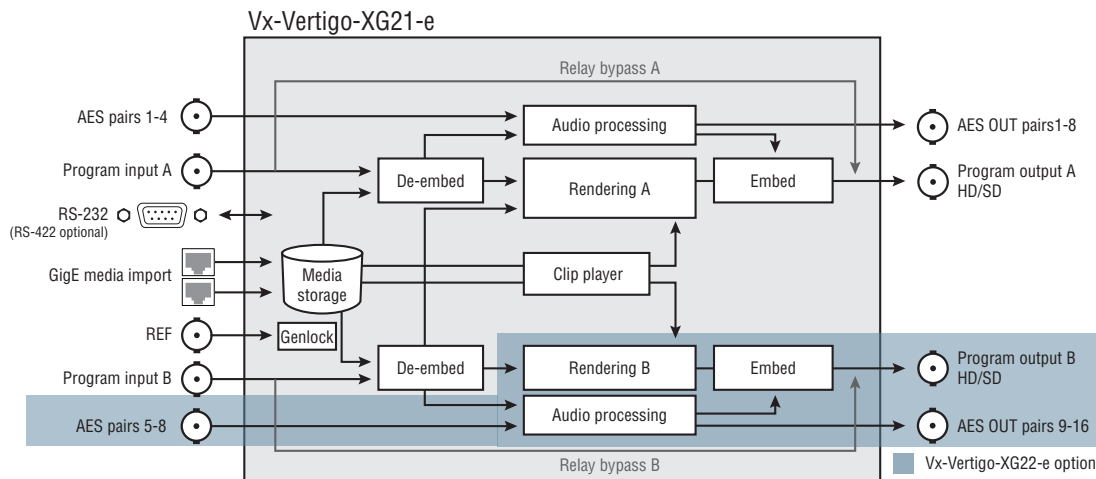

Multi-level clip, animation and still playout

Vertigo XG provides all the playout capabilities needed for the most advanced branding and promotional graphics:



Playout of one or more clips allows creation of advanced promotional graphics effects

Multi-format clip player

The video/audio clip player can output multiple clips simultaneously, and features storage for up to 400 hours of clips in multiple formats:

- > Ideal for playout of full screen or partial screen clips
- > Designed for playout of automated promos, branding interstitials and emergency content
- > Clip player supports MPEG-2 (I frame & Long GOP), MPEG-4 / H.264, DV25, DV50, DV100, IMX30, IMX40, IMX50, MXF, GXF, AVI

Clip storage with different storage options (hours)

Mbps	1 TB	2 TB
10	200	400
50	40	80
100	20	40



Vertigo XG is ideal for highly animated 'Coming up next' graphics

Sophisticated animation controls

The advanced animation and still playout capabilities include:

- > Virtually unlimited layers of animations and still graphics
- > Independent control of each virtual layer
- > Expandable graphics storage of up to 1800 GB using hot-swappable drives
- > Rapid loading of graphics over high speed Ethernet (10/100/1000baseT)
- > Keyframe animation editor and timeline for real-time animation playback, including the following animation types: ping-pong, single shot, in-loop-out, multiple loop with loop delay
- > Animations can be cut or faded to air, and can be moved to create slide transitions, and they can also be used for reveal transitions
- > Graphics can be controlled by 'business logic' to reflect data content, using Vertigo Suite applications



A dual channel DVE is ideal for squeeze back and picture-in-picture effects

Complex, dual channel DVE transitions

- > A high quality, dual channel DVE is ideal for the full breadth of channel branding and promotional transitions
- > DVE effects include triple axis rotation, and many pre-defined 2D and 3D transition effects
- > Easy configuration of picture-in-picture and squeeze and reveal type transitions using Vertigo Suite applications or Branding Panel

Vertigo XG: high quality HD/SD character generation



Advanced multi-level HD/SD character generation with full TrueType / Unicode character support



Complex, data-driven graphics with multiple layers of animated and dynamic text



EAS message insertion with high quality text

Multi-level character generation

A powerful, HD/SD character generator allows the playout of virtually unlimited layers of animated text and dynamically updated text with the following features:

- Wide range of text effects including outlines, drop shadows and gradient fills
- TrueType and Unicode character support for high quality display of Latin and non-Latin text
- Text can be transitioned onto the screen by fades, slides, wipes and many other 2D and 3D effects
- Full control of the speed of each crawl layer
- Looping and single pass crawls

Effective data interfacing

When combined with the Vertigo Suite applications, Vertigo XG offers the most advanced data-interfacing capabilities for multiple applications, including sports, weather, elections and channel promotions:

- Interfacing to Microsoft Excel files, XML, RSS feeds, web data, and multiple databases, including MS-Access, MS-SQL, Oracle and all ODBC-compliant databases
- Interfacing to proprietary data feeds, including Reuters, AP, SportsTicker, and Bloomberg

Emergency alert graphics

High quality EAS text and audio can be played out with the Vertigo XG processor, using templates which integrate channel branding graphics for a consistent on-air presentation.

ORDERING INFORMATION

VX-Vertigo-XG21-e	Vertigo XG single channel graphics engine (2 inputs, 1 output), 3RU
VX-Vertigo-XG22-e	Vertigo XG dual channel graphics engine (2 inputs, 2 outputs), 3RU

Options

VX-RS422-e	2 port RS-422/485 card
VX-Audio-e	Discrete audio
VX-GPI-8-e	GPI card
VX-TC-e	Time Code card
VX-ClipPlayer	Clip player

Key solution options

Vx-Preview-FX	Software CG option for Xstudio (to preview Tweets rendering)
Vx-Studio-Pro-Standalone	Advanced authoring tool

* Available in USA only

Miranda/Quest on-screen Twitter graphics and channel branding solution*

Vx-Vertigo-Quest-BDL	Twitter and channel branding graphics solution
----------------------	--

Boost audience engagement and sponsorship revenues with Twitter television graphics

Now you can boost your audience engagement and retention, while also increasing sponsorship revenues, using Twitter television graphics. By highlighting Tweets from presenters and viewers plus Twitter accounts on-air, you can deliver a highly interactive viewer experience.

These social media graphics are easy to deploy, and they create multiple new sponsorship opportunities. Additionally, this social networking requires minimal staffing due to the smart workflows offered by the Miranda and Quest graphics solution*.

The new solution is designed for local stations and national broadcasters in the USA, and represents a tight integration of Miranda's Vertigo XG graphics processor and Quest's Q-Live Twitter social media application.

This system can be used by television presenters to drive live communications with viewers, and it simplifies the tasks of accepting, censoring, and queuing viewers' Tweets. These Tweets can then be manually or automatically displayed On-Air.

Templates for rich and highly animated, social media and channel branding graphics can be quickly prepared, with full integration across Miranda's Vertigo Suite graphics automation tools and Quest's software solutions for local stations. The system allows the full mix of channel branding and promotional graphics to be played out, including lower thirds, junctions, and schedule boards.



Watch our Twitter graphics system in action at WNBC

Our solution can be readily expanded with Miranda's Vertigo Suite graphics workflow tools and Quest's graphics applications (see www.questrd.com).

*Only available in USA

Overview of workflow for integrated on-screen Twitter graphics and channel branding

