

# XVP-3901-XC

## 3Gbps/HD cross-converter with audio processor



The XVP-3901-XC is a highly integrated, 3Gbps/HD cross converter and video/audio signal processor, which is designed to synchronize, cross-convert and process HD signals into 3Gbps/HD hybrid plants. It is identical to the XVP-3901 except that it does not have the up/down conversion capability.

It features a dual 3Gbps/HD/SD input selector and provides multiple outputs of the selected output format. The processor performs all the cross conversion, color space and aspect ratio conversion needed to maintain the chosen output formatting on the outputs, irrespective of whether the input is 3Gbps (Level A or B), HD 1080i or HD 720p.

High quality cross conversion is performed at both 50 and 59.94Hz, based on multiple sophisticated processing technologies. These include detail enhancement, pixel-based de-interlacing, and advanced motion adaptive de-interlacing and anti-ringing.

To ensure that the cross converted video is delivered in the correct aspect ratio when aired, the XVP-3901-XC fully supports AFD. This provides automatic aspect ratio and video size control using embedded commands, and it prevents on-air aspect ratio errors such as the postage stamp effect.

A background keying capability allows side panels (or top and bottom panels) to be filled with graphics to improve on-air presentation.

A fiber input/output plug-in cartridge option significantly simplifies fiber installation and configuration. When the fiber cartridge is fitted, the card can select between fiber and BNC inputs and can output both electrical and optical signals simultaneously.

The processor's audio capabilities are equally advanced, with processing of up to 32 channels of audio, with automatic delay to keep lip sync. The processor provides shuffling and down-mixing, and options include Automatic Loudness Control, dynamic processing (limiter, compressor, and expander), loudness metering, and four AES inputs/outputs for additional flexibility.

The XVP-3901-XC has 2 on-board sockets for optional modules, including Dolby E encoding, Dolby Digital (AC-3) encoding, Dolby E / Dolby Digital (AC-3) decoding, and upmixing using Linear Acoustic upMAX™ technology. Miranda also offers two modules that provide Automatic Loudness Control (ALC). These modules feature award-winning technologies such as AEROMAX™ by Linear Acoustic and Level Magic™ by Jünger Audio which are both proven technologies capable of maintaining constant loudness across different audio programs (see page 78).

There are many benefits to the XVP-3901-XC's high level of feature integration. A lower purchase cost per channel is obviously highly desirable but there are many other dimensions to cost savings that are readily achievable. These include reduced space and cooling costs, less cabling, and a reduced spares inventory. By simplifying video and audio synchronization, and reducing the number of vendors, the system integration is also simplified significantly.

The XVP-3901-XC can be upgraded in the field to the full XVP-3901 specification with up/down/cross conversion capability.

### KEY FEATURES AND BENEFITS

#### Video

- > Cross/ARC converter with frame sync
- > Offers a multi-rate 3Gbps/HD input and 3Gbps/HD outputs
- > Supports 3Gbps level A (mapping 1) and level B
- > Flexible HD/SD/URS reference input
- > Advanced video de-interlacing for best image quality
- > One frame of processing delay for all conversions
- > Automatic ARC using AFD (SMPTE-2016), video index (RP-186) and WSS, with custom and fixed presets
- > Keyer option for filling black pillars and letter box
- > Built-in Proc amp with YUV/RGB color correction and legalizer
- > Processes and converts Ancillary data such as CC (608/708), Time Code and Teletext/OP-47
- > Optional SFP optical plug-in cartridges
- > Serial and GPIO ports for automation control
- > Upgradeable to full XVP-3901 specification
- > Dual fingerprint generation to monitor lip sync on SD and HD outputs

#### Audio

- > 16 channels embedded audio processing (32 channels internal)
- > 4 AES inputs / 4 AES outputs
- > Audio Down mix: 5.1 surround to Lt/Rt or Lo/Ro
- > Optional audio dynamic processor (compressor/limiter/expander)

- > Optional audio loudness meter (LEQ(A) or ITU-R BS. 1770)
- > Dolby E compatible and Metadata processing
- > Perfect audio/video sync plus additional audio user delay of up to 2 seconds
- > Compatible with Miranda audio processing cards using ABUS
- > Compatible with iControl multipoint a/v fingerprint analyzer for lip sync measurement
- > Optional Dolby E / Dolby Digital (AC-3) encoder/decoder modules
- > Optional Linear Acoustic upMAX™ module
- > Optional Automatic Loudness Control module - AEROMAX™ by Linear Acoustic
- > Optional Automatic Loudness Control module - Level Magic™ by Jünger Audio
- > Optional Automatic Loudness Control with Miranda Wideband processing (on-board)

**XVP-3901-XC**

		XVP-3901-XC					
		HD				3G	
Input	Output	720p50	720p59.94	1080i50	1080i59.94	1080p50	1080p59.94
HD	720p50	X		X		X	
	720p59.94		X		X		X
	1080i50	X		X		X	
	1080i59.94		X		X		X
	1080p23.98		X		X		X
	1080pSF23.98		X		X		X
	1080p25	X		X		X	
3G	1080p29.97		X		X		X
	1080p50	X		X		X	
	1080p59.94		X		X		X

Video formats supported.

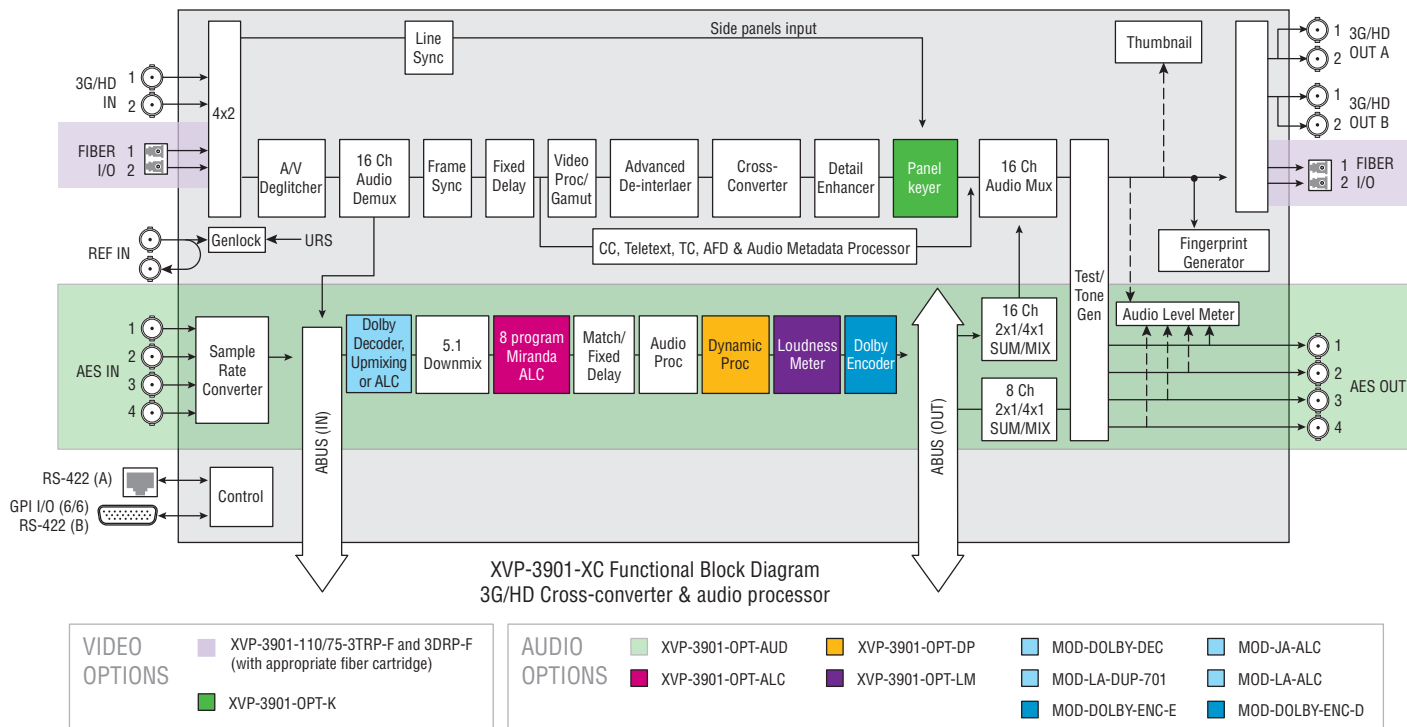

## TECHNICAL SPECIFICATIONS

Refer to XVP-3901 to see technical specifications and rear modules (see pages 93, 94).



## ORDERING INFORMATION

Densité 3 frame	Description
XVP-3901-XC	3Gbps/HD cross-converter with audio processor
XVP-3901-75-3DRP-F	Double rear connector panel, 75 ohm and fiber connector
XVP-3901-110-3DRP-F	Double rear connector panel, 110 ohm and fiber connector
XVP-3901-75-3TRP-F	Triple rear connector panel, 75 ohm and fiber connector
XVP-3901-110-3TRP-F	Triple rear connector panel, 110 ohm and fiber connector
XVP-3901-75-3TRP	Triple rear connector panel, 75 ohm
XVP-3901-110-3TRP	Triple rear connector panel, 110 ohm

Options (software)	Description
XVP-3901-OPT-AUD	AES IO support and 16 channels on-board audio processing option
XVP-3901-OPT-K	Background key input option
XVP-3901-OPT-DP	Dynamic audio processing option
XVP-3901-OPT-LM	Loudness meter option
XVP-3901-UG-XC2XVP	Upgrade from XVP-3901-XC to full XVP
XVP-3901-OPT-ALC-2	2-channel on-board ALC option by Miranda
XVP-3901-OPT-ALC-6	6-channel on-board ALC option by Miranda
XVP-3901-OPT-ALC-8	8-channel on-board ALC option by Miranda
XVP-3901-OPT-ALC-16	16-channel on-board ALC option by Miranda

Options (hardware)	Description
SFP-R-LC	Single fiber Rx (input) cartridge with LC/PC connector
SFP-RR-LC	Dual fiber Rx (input) cartridge with LC/PC connector
SFP-T-S13-LC	Single fiber Tx (output) cartridge at 1310 nm with LC/PC connector
SFP-TT-S13S13-LC	Dual fiber Tx (output) cartridge at 1310 nm with LC/PC connector
SFP-RT-S13-LC	Dual fiber Rx/Tx (input/output) cartridge 1310 nm with LC/PC connector

Other types of SFP Optical Plug-In Cartridges may be available for this product. Please visit [www.miranda.com/SFP](http://www.miranda.com/SFP) for more information.

Options (hardware - continued)	Description
NSH26M	HD-26 to terminal block adapter
BOC-DA26-8BNC-1	75 ohm digital audio breakout cable
MOD-DOLBY-ENC-E	Dolby E encoder
MOD-DOLBY-ENC-D	Dolby Digital (AC-3) encoder
MOD-DOLBY-DEC	Dolby E & Digital (AC-3) decoder
MOD-LA-DUP-701	Upmixing using Linear Acoustic Technology upMAX™
MOD-LA-ALC-2	2-channel ALC licensed by Linear Acoustic
MOD-LA-ALC-6	6-channel ALC licensed by Linear Acoustic
MOD-LA-ALC-8	8-channel ALC licensed by Linear Acoustic
MOD-LA-ALC-2-DUP	2-channel ALC and upmix licensed by Linear Acoustic
MOD-LA-ALC-6-DUP	6-channel ALC and upmix licensed by Linear Acoustic
MOD-LA-ALC-8-DUP	8-channel ALC and upmix licensed by Linear Acoustic
MOD-JA-ALC-2	2-channel ALC licensed by Jünger Audio
MOD-JA-ALC-6	6-channel ALC licensed by Jünger Audio
MOD-JA-ALC-8	8-channel ALC licensed by Jünger Audio
MOD-JA-ALC-2-DUP	2-channel ALC licensed by Jünger Audio and upmix by Linear Acoustic
MOD-JA-ALC-6-DUP	6-channel ALC licensed by Jünger Audio and upmix by Linear Acoustic
MOD-JA-ALC-8-DUP	8-channel ALC licensed by Jünger Audio and upmix by Linear Acoustic

**Remote control** iControl, iControl Solo, RCP-200