

FIO-1841

Description

The FIO-1841 is a serial fiber-to-serial digital video module for the Densité frame. The FIO-1841 is designed for SD and HD serial video as well as compressed bit-streams. The FIO-1841 supports any data rate in the 5 Mbps to 1.5 Gbps range and provides a reclocked serial digital video from 143 Mbps to 1.5 Gbps. The FIO-1841 provides unidirectional fiber dual Rx. The FIO-1841 can be installed in the same chassis as a series of interface modules, providing a wide variety of video, audio and data conversion and multiplexing functions. The FIO-1841 can also come with the optional WDM coupler (FIO-1841-W) which allows the use of a single optical fiber for both inputs.

This card operates with the MSB-1121 Monitoring Switching Bridge which allows the output of any module in the Densité frame to be monitored.

Features and Benefits

- Supports any serial data rate from 5 Mbps to 1.5 Gbps (HD SDI)
- Reclocked serial digital video from 143 Mbps to 1.5 Gbps.
- Supports SMPTE 292M, SMPTE 259M, SMPTE 297M, SMPTE-310M, DVB-ASI.
- Provides unidirectional interface between fiber optic and serial digital.
- Dual RX configuration with optional WDM.
- Convenient front loading design.
- Fully hot swappable.
- Remote monitoring and control.
- Ideal for long video run with "Hum" immunity.
- Provides output to Monitoring Switching Bridge option (SD only).

Functional Block Diagram

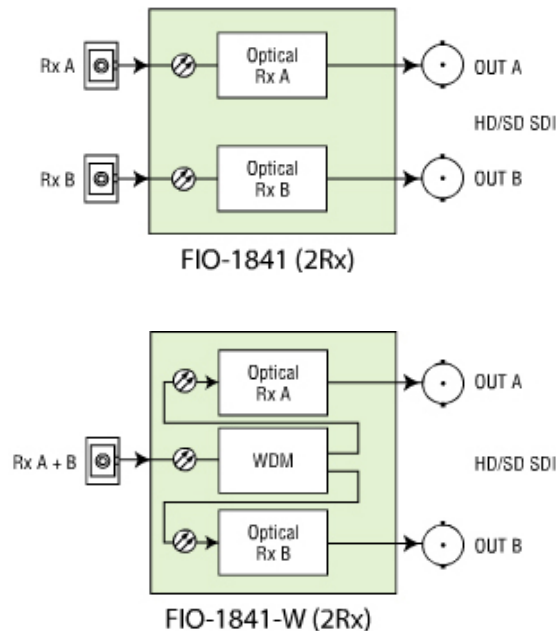

Specifications

Mechanical

I/O connectors: 75 Ω BNC (2)
 Optical SC (2)

Video Output

Signal: SMPTE 292M
 (1.485, 1.485/1.001 Gbps)
 SMPTE 259M-ABCD
 (143, 270, 360, 540 Mbps)
 SMPTE 305M (SDTI)
 SMPTE 310M (19.4 Mbps)
 DVB-ASI (270 Mbps)

Rclk Signal: 143, 270, 360, 540 Mbps and 1.5 Gbps

Return Loss: > 15 dB up to 1.5 GHz

Jitter: < 0.2 UI p-p

Optical Receiver

Signal Compatibility: 19.4 Mbps to 1.5 Gbps
 SMPTE 259M (143-540 Mbps)
 SMPTE 292M (1.485 Gbps)
 SMPTE 297 (Fiber)
 SMPTE 305M (SDTI)
 SMPTE 310 (19.4 Mbps)
 DVB-ASI (270 Mbps)

Wavelength: 1310 nm to 1550 nm

Sensibility: -20 dBm

Fiber Type: Single Mode

FIO-1841 Dual Optical to Electrical Converter Guide to Installation and Operation

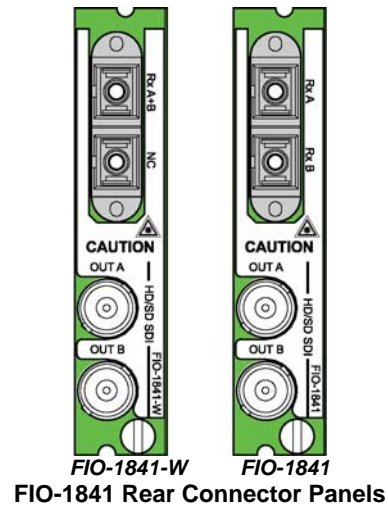
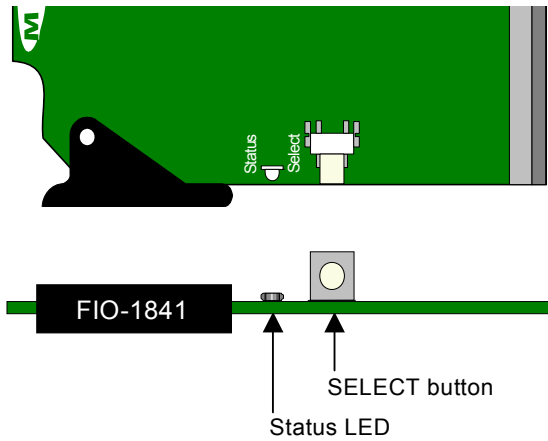

Installation

Make sure you have ordered and received the FIO-1841 and its associated rear panel. If any of the following items are missing, contact your distributor or Miranda Technologies Inc.

- FIO-1841 Dual Optical to Electrical Converter
- FIO-1841-SRP Rear Panel (see figure)

The FIO-1841 must be mounted in a DENSITÉ frame. The installation includes both the FIO-1841 module, and the rear panel module. It is not necessary to switch off the power from these frames when installing or removing the FIO-1841.

Note: Before attempting to install the FIO-1841 module in the DENSITÉ frame, ensure that the protective caps on the fiber ends of the SC connectors have been removed (a factory-applied sticker will remind you to do this).

Detailed instructions for installing cards and their associated rear panels in the DENSITÉ frame are given in the DENSITÉ Frame manual.

Operation

Overview

The DENSITÉ frame incorporates a central controller card, located in the center of the frame. It is equipped with an LCD display and control panel. The controller handles error reporting and local and remote control for all cards installed in the frame. The display and control panels are assigned to the card in the frame whose SELECT button has been pushed.

User Interface

Pushing the SELECT button will cause the on-card STATUS LED to flash yellow. The card identification and the current status will be shown on the controller card's display. The STATUS LED will revert to its normal state upon a second push of the button, or after a short delay.

The messages which may appear are shown in the top line of the menu chart on page 3.

Status Monitor LED

The status monitor LED is located on the front card-edge of the FIO-1841 module, and is visible through the front access door of the DENSITÉ frame. This multi-color LED indicates module status by color, and by flashing/steady illumination, according to the following chart (which also indicates fault reporting for this card on the DENSITÉ frame's serial and GPI interfaces).

| | Serial Report | GPI Report | Green | Yellow | Red | Flash Red |
|---------|---------------|------------|-------|--------|-----|-----------|
| No Rear | ✱ | | | | | ✱ |
| No Rx A | ✱ | | | | ✱ | |
| No Rx B | ✱ | | | | ✱ | |

✱ : Factory default.

The LED color assignments of some error conditions can be reconfigured by the user (see chart and menu for details).

Push the SELECT button on the FIO-1841 card edge to show its status on the DENSITÉ frame's controller card display (the STATUS LED flashes yellow).

Example:

| | | | | | | | | | | | | | | |
|---|---|---|---|---|---|---|---|--|--|--|--|--|--|--|
| F | I | O | - | 1 | 8 | 4 | 1 | | | | | | | |
| N | O | S | I | G | N | A | L | | | | | | | |

Use the local control panel to access the detailed status report shown in the STATUS menu next page.

FIO-1841 Card Menu

Operating Parameter Adjustment

The FIO-1841 has operating parameters which may be adjusted locally at the controller card interface. After

pressing the SELECT button on the FIO-1841 module, use the keys on the local control panel (described in the Controller card manual) to step through the displayed menu and adjust the parameters. The menus are shown below

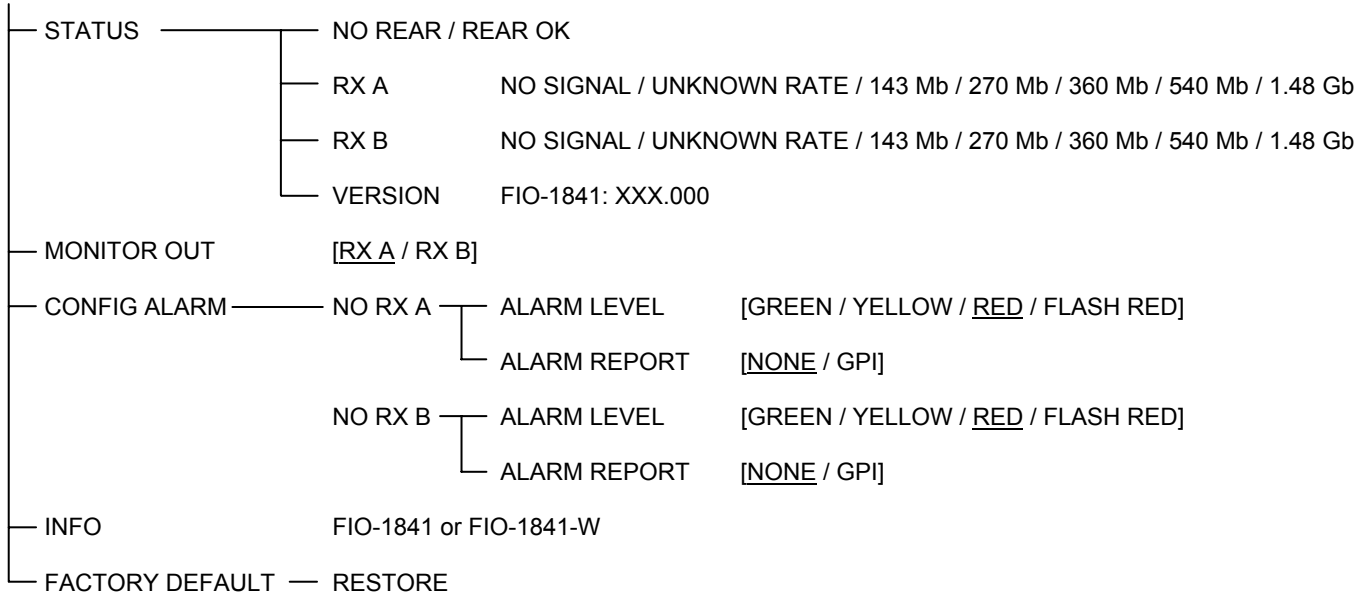

Lists in [square brackets] indicate a selectable choice. The factory default value is underlined

Operation (cont'd)

STATUS Menu

Displays the status of some FIO-1841 parameters.

NO REAR: indicates the absence of the rear panel or an incompatibility between the module and the rear panel. The STATUS led turns on flashing red.

REAR OK: indicates the presence of a compatible rear panel.

RX A and RX B

NO SIGNAL, UNKNOWN RATE: indicates a faulty incoming signal, either because no input signal is detected or because the input signal data rate is not recognized by the module.

143 Mb, 270 Mb, 360 Mb, 540 Mb, 1.48 Gb: Indicates the input signal data rate.

VERSION: FIO-1841, XXX.000: shows the microcontroller firmware version.

MONITOR OUT menu

RX A / RX B: Select which of the two inputs to send to the Monitoring Switching Bridge (MSB) card in the Densité frame (if present).

CONFIG ALARM menu

The FIO-1841 detects errors or non-standard operating conditions for a number of parameters. This menu allows the response of the card to be set for each of these situations.

ALARM LEVEL: Associates a STATUS LED color (GREEN, YELLOW, RED or FLASH RED) with each error or condition.

ALARM REPORT: Select GPI to activate an alarm relay* when an error is detected. The default value is NONE.

* Note: Alarm relay activation can only occur if the parameter GPI REPORT is enabled in the menu of the Densité frame's controller card.

INFO menu

FIO-1841, FIO-1841W: gives the product name.

FACTORY DEFAULT menu

Reset all the parameters to their original factory-preset values underlined in the menu.

FIO-1841 Dual Optical to Electrical Converter Guide to Installation and Operation

COMPLIANCE

Radio Frequency Interference and Immunity

This unit generates, uses, and can radiate radio frequency energy. If the unit is not properly installed and used in accordance with this guide, it may cause interference with radio communications. Operation with non-certified peripheral devices is likely to result in interference with radio and television reception. This equipment has been tested and complies with the limits in accordance with the specifications in:

FCC Part 15, Subpart B; CE EN50081-1:1992; CE EN50082-1:1992.

CONTACT MIRANDA

For technical assistance, please contact the Miranda Technical support centre nearest you:

Americas

Telephone:

+1-800-224-7882

e-mail:

techsupp@miranda.com

Asia

Telephone:

+81-3-5730-2987

e-mail:

asiatech@miranda.com

Europe, Middle East, Africa, UK

Telephone:

+44 (0) 1491 820222

e-mail:

eurotech@miranda.com

France (only)

Telephone:

+33 (0) 1 55 86 87 88

e-mail:

eurotech@miranda.com

Visit our web site at www.miranda.com