

NV5100MC Master Control

Tally Processor User's Guide



Miranda Technologies Inc.
3499 Douglas B. Floreani
Montreal, Quebec
Canada H4S 2C6

NV5100MC/NV5128-MC Tally Processor User's Guide

- **Revision:** 1.5
- **Software Version:** 6.3.6.0
- **Part Number:** UG0036-05
- Copyright: © 2011 Miranda Technologies. All rights reserved.
- No part of this manual may be reproduced in any form by photocopy, microfilm, xerography or any other means, or incorporated into any information retrieval system, electronic or mechanical, without the written permission of Miranda Technologies, Inc.
- The information contained in this manual is subject to change without notice or obligation.
- All title and copyrights as well as trade secret, patent and other proprietary rights in and to the Software Product (including but not limited to any images, photographs, animations, video, audio, music, test, and “applets” incorporated into the Software Product), the accompanying printed materials, and any copies of the Software Product, are owned by Miranda Technologies, Inc. The Software Product is protected by copyright laws and international treaty provisions. Customer shall not copy the printed materials accompanying the software product.

Notice

The software contains proprietary information of Miranda Technologies, Inc. It is provided under a license agreement containing restrictions on use and disclosure and is also protected by copyright law. Reverse engineering of the software is prohibited.

Due to continued product development, the accuracy of the information in this document may change without notice. The information and intellectual property contained herein is confidential between Miranda and the client and remains the exclusive property of Miranda. If you find any problems in the documentation, please report them to us in writing. Miranda does not warrant that this document is error-free.

FCC Statement

This equipment has been tested and found to comply with the limits for a Class A digital device, pursuant to part 15 of the FCC Rules. These limits are designed to provide reasonable protection against harmful interference when the equipment is operated in a commercial environment. This equipment generates, uses, and can radiate radio frequency energy and, if not installed and used in accordance with the instruction manual, may cause harmful interference to radio communications. Operation of this equipment in a residential area is likely to cause harmful interference in which case the user will be required to correct the interference at his own expense.

Declaration of Conformance (CE)

All of the equipment described in this manual has been designed to conform with the required safety and emissions standards of the European Community. Products tested and verified to meet these standards are marked as required by law with the CE mark. (See [Symbols and Their Meanings](#) on page v.)

Change History

The table below lists the changes to the Master Control Tally Processor User's Guide.

- Tally Processor User's Guide Part # UG0036-05
- Software version: 6.3.6.0

Rev	Date	ECO	Description	Approved By
1.0	21 Jan 09	15478	Initial release.	D. Cox
1.1	28 Apr 09	15757	Format change. Released with general software revision 6.1.0, but there are no changes in the product or this guide.	D. Cox
1.2	27 Aug 09	16036	Released with general software revision 6.2.0, but there are no changes in the product or this guide.	D. Cox
1.3	17 Feb 11	16257	Released with general software revision 6.3.1, but there are no changes in the product or this guide.	D. Cox
1.4	28 Jun 10	17086	Released with general software revision 6.3.4, but there are no changes in the product or this guide.	D. Cox
1.5	17 Feb 11	17447	Released with general software revision 6.3.6, but there are no changes in the product or this guide.	D. Cox

Important Safeguards and Notices

This section provides important safety guidelines for operators and service personnel. Specific warnings and cautions appear throughout the manual where they apply. Please read and follow this important information, especially those instructions related to the risk of electric shock or injury to persons.

Warning

Any instructions in this manual that require opening the equipment cover or enclosure are for use by qualified service personnel only. To reduce the risk of electric shock, do not perform any service other than that contained in the operating instructions unless you are qualified to do so.

Symbols and Their Meanings



The lightning flash with arrowhead symbol within an equilateral triangle alerts the user to the presence of dangerous voltages within the product's enclosure that may be of sufficient magnitude to constitute a risk of electric shock to persons.



The exclamation point within an equilateral triangle alerts the user to the presence of important operating and maintenance/service instructions.



The Ground symbol represents a protective grounding terminal. Such a terminal must be connected to earth ground prior to making any other connections to the equipment.



The fuse symbol indicates that the fuse referenced in the text must be replaced with one having the ratings indicated.



The presence of this symbol in or on Miranda equipment means that it has been designed, tested and certified as complying with applicable Underwriter's Laboratory (USA) regulations and recommendations.



The presence of this symbol in or on Miranda equipment means that it has been designed, tested and certified as essentially complying with all applicable European Union (CE) regulations and recommendations.

General Warnings

A warning indicates a possible hazard to personnel which may cause injury or death. Observe the following general warnings when using or working on this equipment:

- Heed all warnings on the unit and in the operating instructions.
- Do not use this equipment in or near water.
- This equipment is grounded through the grounding conductor of the power cord. To avoid electrical shock, plug the power cord into a properly wired receptacle before connecting the equipment inputs or outputs.
- Route power cords and other cables so they are not likely to be damaged.
- Disconnect power before cleaning the equipment. Do not use liquid or aerosol cleaners; use only a damp cloth.
- Dangerous voltages may exist at several points in this equipment. To avoid injury, do not touch exposed connections and components while power is on.
- Do not wear rings or wristwatches when troubleshooting high current circuits such as the power supplies.
- To avoid fire hazard, use only the specified fuse(s) with the correct type number, voltage and current ratings as referenced in the appropriate locations in the service instructions or on the equipment. Always refer fuse replacements to qualified service personnel.
- To avoid explosion, do not operate this equipment in an explosive atmosphere.
- Have qualified service personnel perform safety checks after any service.

General Cautions

A caution indicates a possible hazard to equipment that could result in equipment damage. Observe the following cautions when operating or working on this equipment:

- When installing this equipment, do not attach the power cord to building surfaces.
- To prevent damage to equipment when replacing fuses, locate and correct the problem that caused the fuse to blow before re-applying power.
- Use only the specified replacement parts.
- Follow static precautions at all times when handling this equipment.
- This product should only be powered as described in the manual. To prevent equipment damage, select the proper line voltage on the power supply(ies) as described in the installation documentation.
- To prevent damage to the equipment, read the instructions in the equipment manual for proper input voltage range selection.
- Some products include a backup battery. There is a risk of explosion if the battery is replaced by a battery of an incorrect type. Dispose of batteries according to instructions.
- Products that have (1) no on/off switch and (2) use an external power supply must be installed in proximity to a main power output that is easily accessible.



Table of Contents

Chapter 1	Tally Processor	1
	Introduction	1
	External Features	2
	Front	2
	Rear	2
	Initial Setup	3
	Entering IP and Mask	3
	Set the IP address	3
	Using the Configuration Tool	4
	System	5
	Protocol Assignment	6
	PHY Config	6
	Event Definitions	6
	Event Monitoring	9
	GPI	11
	GPO	12
	Combinational Events	13
	Remote Events	15
Chapter 2	Misc.	17
	PC Configuration	17
	Connectors	19
	GPIO	19
	Power	20
	Notes	20
	General	20
	Saved Files	20
	Under System Menu	20
Index	21

Table of Contents

1. Tally Processor

Miranda offers a third-party “tally processor” as an adjunct to its master control system. It is a GTP-32 from DNF Controls. Because it is third-party equipment, support for it is limited.

This brief guide is the only documentation for the tally processor. There is none from the manufacturer.

Introduction

The “tally processor” is a IRU device, 8.5” deep, that has 32 optically isolated inputs and 32 relay outputs (also optically isolated).

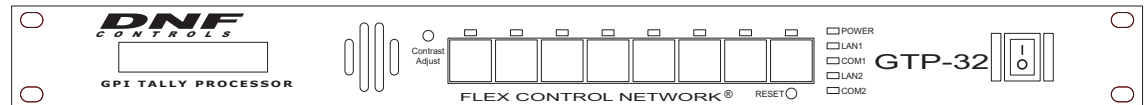

Figure 1-1. Tally Processor, Front View

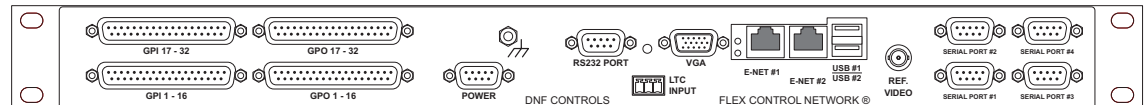

Figure 1-2. Tally Processor, Rear View

The tally processor can receive signals from, and send signals to, an MCPM or MCE using Miranda’s NVISION Ethernet protocol (NVEP).

Multiple tally processors can be connected together over the master control network.

The tally processor is configurable with a small self-contained application that runs in a browser such as Internet Explorer. The objective of configuration is to create an event list that senses either master control events or switch inputs and generates either master control events or controls switch outputs.

The tally processor allows you to

- Control multiple outputs with a single input.
- Control a single output with multiple inputs.

A combinational logic component allows you to control an output according to Boolean expressions involving switched inputs and master control events.

See [Connectors](#) on page 19 for connector details.

1. Tally Processor

External Features

External Features

Front

The unit includes, at the front, a 2×16 character display, an 8-key button pad, several LED indicators, and other items:

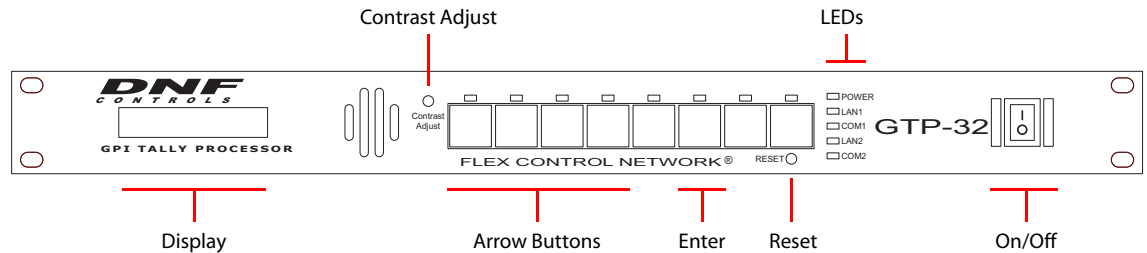

The display is for rudimentary configuration (such as setting the device's IP address) and status.

The leftmost 4 buttons are up, down, left, and right arrow buttons, used for navigating the basic configuration options. Use the 'Enter' button to commit configuration changes.

The LEDs indicate power, and the health of LANs 1 and 2 and COM ports 1 and 2.

You may ignore the recessed reset switch and contrast adjustment.

Rear

The unit includes, at the rear, GPIO, power and Ethernet connectors:

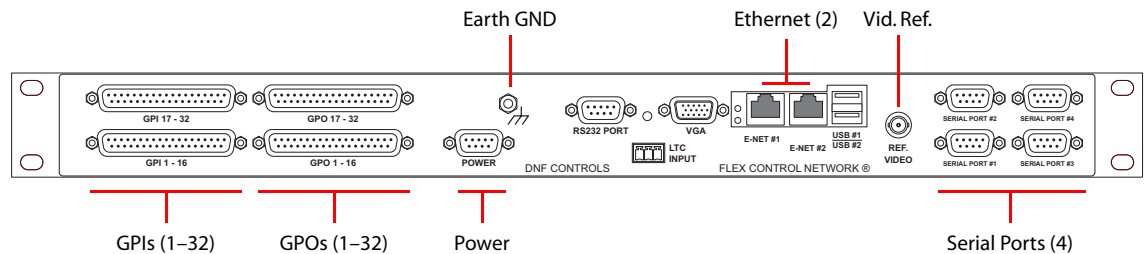

You may ignore the serial ports, the video reference, and any of the ports not identified in this illustration.

Use the GPI and GPO connectors (DC37s) to wire GPIO connections. See [Connectors](#) on page 19 for the pinouts.

Use one of the Ethernet (RJ-45) connectors to connect the tally processor to the master control network.

- ▲ Up to 4 control panels may communicate with any one MCPM or MCE. A tally processor counts as one of the control panels.

The power connector is a DE9. It connects to the external power supply that ships with the tally processor. It is recommended that you connect the ground terminal to earth ground, but not strictly necessary.

Initial Setup

This is the basic procedure.

- 1 Plug in the tally processor at the DE9 power connection. Use the external power supply provided.
- 2 Use a CAT5 Ethernet cable to connect the tally processor to the Ethernet switch servicing the master control network. Use the port labeled “E-net #1.”
Using the front panel of the tally processor, enter its IP address on the master control network and verify that its mask is 255.255.255.0.
- 3 Cable the GPIOs (on the 4 DC37 connectors) to whatever devices you are using according to the design of your system. See [Connectors](#) on page 19 for the pinouts.

- 4 Using your configuration PC (presumed to be on the master control network already), launch your browser (e.g., Internet Explorer). Enter the IP address of the tally processor as the URL:

`http://192.168.102.112` (This is just an example)

The tally processor will run its self-contained configuration application:

`http://192.168.102.112/cgi-bin/index.cgi`

in which you may configure the tally processor’s event list, inputs, and outputs.

Before you can configure anything, you must enter your ID and password. The default or initial ID and password are (admin, controls). You can change the ID and password.

(You can change the time and date using the ‘System’ option of the configuration software.)

Entering IP and Mask

The front panel has a 2×16 character display and 8 function buttons.

Four of the function buttons (at the left) are arrows. The sixth button is ‘Enter’. These buttons are used to navigate through the tally processor’s menu system.

To scroll through the list of options, press the up or down arrows until you come to an option you want to set or change.

Set the IP address

Scroll up or down so that the display shows ‘Current IP1’. Press ‘Enter’.

An underline cursor appears at the first digit of the IP address. Use the left and right arrows to move to a digit you want to change. Then use the up/down arrows to change the value of the digit. When you have finished, press ‘Enter’ once again.

▲ Pressing the ‘Esc’ button terminates the operation and leaves the value unchanged.

Do the same for the IP subnet mask. (The display should read ‘Current Mask1’.) The value should be 255.255.255.0.

1. Tally Processor

Using the Configuration Tool

Using the Configuration Tool

When you launch the internal DNF configuration tool in your browser, its initial screen is this:

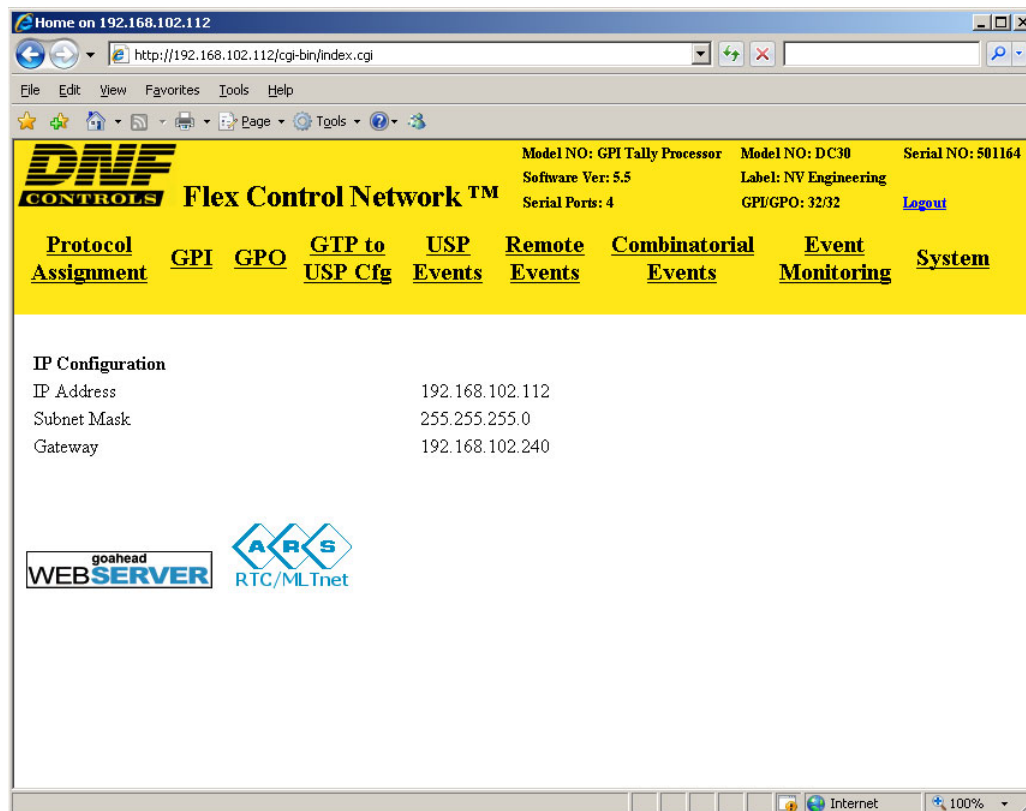

It presents 9 options (sub-pages) listed across the top in the yellow region:

Protocol assignment	Define connections to MCEs and MCPMs and master control events.
GPI	Configure any or all of the 32 GPIs.
GPO	Configure any or all of the 32 GPOs.
GTP to USP Cfg	Ignore this unless you have a USP. ^a
USP events	Ignore this unless you have a USP.
Remote events	Events coming from another tally processor on the network.
Combinational events	Logic expression based on inputs and master control events.
Event monitoring	Defines what the events to monitor are and what to do when the events occur and when they expire.
System	Presents a login dialog and provides configuration options for the tally processor (to which you are connected) and its software.

a. Miranda does not provide any support for the USP (Universal Switch Panel)—a separate DNF product.

Each sub-page manages a configuration table. Configuration tables can be saved and retrieved for fast setups and quick changes during a broadcast or production.

Descriptions of the sub-pages follow.

System

If you are not logged in, clicking the ‘System’ option presents a login dialog:

logged out

Username:

Password:

The default ID is admin and the default password is controls.

▲ The login times out after a few minutes. After any period of non-use, you might find the configuration tool asking for your password again.

After you are logged in, the ‘System’ option presents a list of configuration options (where you can set your password, among other things).

Current User: admin

Current Time: January / 5 / 2009 10:37:04

Startup Time: January / 5 / 2009 09:49:11

- [Set Admin Password](#)
- [Set System Time](#)
- [Set System Label](#)
- [Set System Port Number](#)
- [Configure SNMP - \(SNMP is not Licensed\).](#)
- [Configure GTP Operation Mode](#)
- [Restart the System](#)

- [Diagnostics](#)
- [Logout](#)
- [System maintenance](#)
- [VTR Control](#)

Other than password and system time, the items in this page are of little concern.
(Miranda does not support the ‘VTR Control’ feature.)

1. Tally Processor

Using the Configuration Tool

Protocol Assignment

The tally processor supports up to 4 channels (MCEs or MCPMs). This table on this page lists the channels and defines the events of interest on each channel. The event types are defined in Miranda's NVISION Ethernet protocol (NVEP).

The example in this illustration shows two channels defined, both Ethernet and both using NVEP.

[Edit Protocol Assignment Table](#)

Last Updated: December / 5 / 2008 16:20:05

PROTOCOL ASSIGNMENT TABLE

Channel	Physical Connector	Channel Label	Control Protocol	Control Function	Device Config	PHY Config	Event Definitions	Status
1	Ethernet_1	Dot124	nvep	Switcher Monitor and Control	N/A	View Edit	Monitor Control	Connected
2	Ethernet_1	Dot125	nvep	Switcher Monitor and Control	N/A	View Edit	Monitor Control	Connected
3	Serial_3	label2	Unassigned	N/A	Unassigned	N/A	N/A	No Comm
4	Serial_4	label3	Unassigned	N/A	Unassigned	N/A	N/A	No Comm

List of licensed protocols and functions:

Protocols:	nvep, menu,	Functions:	Combinatorial Logic, Logging, Switcher Control,
-------------------	-------------	-------------------	--

You can edit the table, but you cannot add or delete items. Of the entries in the table, 'PHY Config' and 'Event Definitions' are the most important. It is in the 'Event Definitions' column that you specify the master control events you want to sense or to control.

PHY Config

There are two options: view or edit the IP address of the MCE or MCPM with which you want to communicate.

Event Definitions

There are two classes of events in this context: monitor events (inputs) and control events (outputs).

You can view, add, delete, and edit events by clicking on the word 'Monitor' or 'Control' for the table entry of choice.

Control Events

Control events play an important role in the 'Event Monitoring' table. It is through these event types that you can control an MCE or MCPM. These are the choices for the control event type:

PGM_AV_TAKE	PRSET_AV_TAKE
PGM_VIDEO_TAKE	PRSET_VIDEO_TAKE
PGM_AUDIO_TAKE	PRSET_AUDIO_TAKE
PGM_AUDIO_OVER	PRSET_AUDIO_OVER
PGM_KEYER	PRSET_KEYER
PGM_LOGO	PRSET_LOGO
PGM_SQUEEZE	PRSET_SQUEEZE
TRANSITION	

Except for "transition," these control events act as immediate program or preset "button presses."

A control event includes an integer value and an action. The choices for action depend on the event type chosen.

Keyer, logo, squeeze actions are 'ON' or 'OFF'. The integer represents the keyer, logo, or squeeze-back number. Keyer numbers include 1, 2, and 3. Logo numbers include 1 (meaning logo A) and 2 (meaning logo B). The squeezeback is 1 or not relevant.

1. Tally Processor

Using the Configuration Tool

Audio over actions are 'ON' or 'OFF'. The integer represents the over number, 1 or 2.

The only action for all other types is 'TAKE'. The integer for takes is the source button number (1–16) in the MCE/MCPM. The integer for transition is irrelevant.

The transition control event acts as if it were a transition button press. It starts a master control transition. The integer does not apply to transition events.

This is a sampling of control events:

[Add / Edit / Delete / Backup / Restore](#) Table.

Switcher Control Definitions

Control Event Label	Description	Type	Value	Action
PGM1	1	PGM_AV_TAKE	1	TAKE
PGM2	2	PGM_AV_TAKE	2	TAKE
PGM3	3	PGM_AV_TAKE	3	TAKE
PGM4	4	PGM_AV_TAKE	4	TAKE
PGM5	5	PGM_AV_TAKE	5	TAKE
PGM6	6	PGM_AV_TAKE	6	TAKE
PGM7	7	PGM_AV_TAKE	7	TAKE
PGM8	8	PGM_AV_TAKE	8	TAKE
PST1	9	PRSET_AV_TAKE	1	TAKE
PST2	10	PRSET_AV_TAKE	2	TAKE
PST3	11	PRSET_AV_TAKE	3	TAKE
PST4	12	PRSET_AV_TAKE	4	TAKE
PST5	13	PRSET_AV_TAKE	5	TAKE
PST6	14	PRSET_AV_TAKE	6	TAKE
PST7	15	PRSET_AV_TAKE	7	TAKE
PST8	16	PRSET_AV_TAKE	8	TAKE
Transition	Transition	TRANSITION	0	TAKE

Monitor Events

These are the choices for the monitor event type:

PGM_VIDEO_XPT PRSET_VIDEO_XPT
PGM_AUDIO_OVER PRSET_AUDIO_OVER
PGM_KEYER PRSET_KEYER
TRANSITION

Except for "transition," these monitor events occur when an operator (or automation) makes a program or preset "button press."

A video XPT event includes an integer value and a relational operator. The integer is the MCPM/MCE crosspoint number (1–16), equivalent to a panel button number.

An audio over event includes an integer value and a relational operator. The integer is the over number (1,2).

A transition event is either 'ON' or 'OFF'. The integer does not apply.

A keyer event is either 'ON' or 'OFF'. The integer is the keyer number (1,2,3).

The relational operators include =, !=, >, >=, <, and <= and have the same meaning as in the C programming language.

There are no monitor events for logos or squeezeback effects.

1. Tally Processor

Using the Configuration Tool

This is a sampling of monitor events:

[Add](#) / [Edit](#) / [Delete](#) / [Backup](#) / [Restore](#) Table.

Switcher Monitoring Definitions

Event Label	Description	Type	Value	Condition
Preset_XPT_1	Preset_XPT_1	PRSET_VIDEO_XPT	1	=
Preset_XPT_2	Preset_XPT_2	PRSET_VIDEO_XPT	2	=
Preset_XPT_3	Preset_XPT_3	PRSET_VIDEO_XPT	3	=
Preset_XPT_4	Preset_XPT_4	PRSET_VIDEO_XPT	4	=
Preset_XPT_5	Preset_XPT_5	PRSET_VIDEO_XPT	5	=
Preset_XPT_6	Preset_XPT_6	PRSET_VIDEO_XPT	6	=
Preset_XPT_7	Preset_XPT_7	PRSET_VIDEO_XPT	7	=
Preset_XPT_8	Preset_XPT_8	PRSET_VIDEO_XPT	8	=
Transition	Transition	TRANSITION	N/A	ON
Program_XPT_1	PGM1	PGM_VIDEO_XPT	1	=
Program_XPT_2	PGM2	PGM_VIDEO_XPT	2	=
Program_XPT_3	PGM3	PGM_VIDEO_XPT	3	=
Program_XPT_4	PGM4	PGM_VIDEO_XPT	4	=
Program_XPT_5	PGM5	PGM_VIDEO_XPT	5	=
Program_XPT_6	PGM6	PGM_VIDEO_XPT	6	=
Program_XPT_7	PGM7	PGM_VIDEO_XPT	7	=

Event Monitoring

The ‘Event Monitoring’ table defines what the tally processor will do when it senses an event. Events include GPI switches, master control events, and changes to the state of combinatorial logic expressions.

For each event monitored, the table specifies what to do and which GPO to trigger (and whether to trigger it) when the event occurs.

When you add an event to this table, you define the label (a unique ID) for the event.

[Add / Edit / Delete / Backup / Restore Channel Event](#)
[Create Default Event Monitor Table](#)
 Currently used file is not a restored file.

Last Refreshed: December / 5 / 2008 16:46:26

EVENT MONITORING TABLE

Status	Source IP	Connection Status	Event Label	Event Status	Frequency	GPO Label	ON Function	OFF Function
Enabled	0.0.0.0	Local	CH_1_Preset_XPT_1	OFF	Repetitive	GPO_9	Turn On GPO	Turn Off GPO
Enabled	0.0.0.0	Local	CH_1_Preset_XPT_2	OFF	Repetitive	GPO_10	Turn On GPO	Turn Off GPO
Enabled	0.0.0.0	Local	CH_1_Preset_XPT_3	OFF	Repetitive	GPO_11	Turn On GPO	Turn Off GPO
Enabled	0.0.0.0	Local	CH_1_Preset_XPT_4	ON	Repetitive	GPO_12	Turn On GPO	Turn Off GPO
Enabled	0.0.0.0	Local	CH_1_Preset_XPT_5	OFF	Repetitive	GPO_13	Turn On GPO	Turn Off GPO
Enabled	0.0.0.0	Local	CH_1_Preset_XPT_6	OFF	Repetitive	GPO_14	Turn On GPO	Turn Off GPO
Enabled	0.0.0.0	Local	CH_1_Preset_XPT_7	OFF	Repetitive	GPO_15	Turn On GPO	Turn Off GPO
Enabled	0.0.0.0	Local	CH_1_Preset_XPT_8	OFF	Repetitive	GPO_16	Turn On GPO	Turn Off GPO
Enabled	0.0.0.0	Local	CH_1_Program_XPT_1	ON	Repetitive	GPO_1	Turn On GPO	Turn Off GPO
Enabled	0.0.0.0	Local	CH_1_Program_XPT_2	OFF	Repetitive	GPO_2	Turn On GPO	Turn Off GPO
Enabled	0.0.0.0	Local	CH_1_Program_XPT_3	OFF	Repetitive	GPO_3	Turn On GPO	Turn Off GPO
Enabled	0.0.0.0	Local	CH_1_Program_XPT_4	OFF	Repetitive	GPO_4	Turn On GPO	Turn Off GPO
Enabled	0.0.0.0	Local	CH_1_Program_XPT_5	OFF	Repetitive	GPO_5	Turn On GPO	Turn Off GPO
Enabled	0.0.0.0	Local	CH_1_Program_XPT_6	OFF	Repetitive	GPO_6	Turn On GPO	Turn Off GPO
Enabled	0.0.0.0	Local	CH_1_Program_XPT_7	OFF	Repetitive	GPO_7	Turn On GPO	Turn Off GPO
Enabled	0.0.0.0	Local	CH_1_Program_XPT_8	OFF	Repetitive	GPO_8	Turn On GPO	Turn Off GPO
Enabled	0.0.0.0	Local	CH_2_Preset_XPT_1	OFF	Repetitive	GPO_25	Turn On GPO	Turn Off GPO
Enabled	0.0.0.0	Local	GPI_23	OFF	Repetitive	GPO_23	CH_2_23	Do Nothing
Enabled	0.0.0.0	Local	GPI_24	OFF	Repetitive	GPO_24	CH_2_24	Do Nothing
Enabled	0.0.0.0	Local	GPI_25	OFF	Repetitive	GPO_25	CH_2_25	Do Nothing
Enabled	0.0.0.0	Local	GPI_26	OFF	Repetitive	GPO_26	CH_2_26	Do Nothing
Enabled	0.0.0.0	Local	GPI_27	OFF	Repetitive	GPO_27	CH_2_27	Do Nothing
Enabled	0.0.0.0	Local	GPI_28	OFF	Repetitive	GPO_28	CH_2_28	Do Nothing
Enabled	0.0.0.0	Local	GPI_29	OFF	Repetitive	GPO_29	CH_2_29	Do Nothing
Enabled	0.0.0.0	Local	GPI_30	OFF	Repetitive	GPO_30	CH_2_KeyOn1	CH_2_Key1Off
Enabled	0.0.0.0	Local	GPI_31	OFF	Repetitive	GPO_31	CH_2_PSTK1On	CH_2_PSTK1Off
Enabled	0.0.0.0	Local	GPI_32	OFF	Repetitive	GPO_32	CH_2_TRAN	CH_2_PSTK1Off

An event is considered ON when its underlying definition evaluates ON. It is OFF, otherwise.

An event has a function configured to perform one of many tasks when the event status becomes ON and another function that does something when the event status is OFF. One of the options is “do nothing”.

An event might or might not affect a GPO but it is always associated with one of the GPOs.

An event may be classified as *repetitive* or *single*. *Repetitive* means that the input can be sampled whenever it occurs. *Single* means that the input is monitored until it goes on and thereafter it is not monitored.

1. Tally Processor

Using the Configuration Tool

Adding Events

An event dialog appears when you choose ‘Add’ (above or below the table).

- Assign source event to GPO.
- Source event may be local or remote event.
- For REMOTE EVENT, enter Source IP and Source Event Label.
- GPO may be any local GPO.
- Duplicate entries will not be saved!
- **Warning** Events in **Pending** State will not be processed! Click [here](#) to enable.

Add Event to Channel Event Monitoring

Status	Enabled ▾
Source IP	0.0.0.0
Source Event Type	LOCAL EVENT ▾
Source Event Label	GPI EVENTS: ▾
Frequency	Repetitive ▾
ON Function	Do Nothing ▾
OFF Function	Do Nothing ▾
GPO Label	GPO_1 ▾

An event may be local or remote. If it is remote, enter the IP address of the remote tally processor and the remote label for the event. If it is local, the label drop-down list will be filled with a number of options which include GPIs, combinational events, master control events, and other kinds of events.

- ▲ Some of the inputs that the tally processor monitors to decide whether an event occurs come through the LAN, via NVEP, from the master control system.
- ▲ Duplicate entries overwrite older entries.

Choose whether the event monitoring is *repetitive* or *single*.

Choose the ON function and the OFF function. Some of the ON and OFF functions turn a GPO on or OFF. An event in the list always involves one of the GPOs, but it is meaningful only if the function is to turn the GPO on or off. The function ‘Do Nothing’ is available if you do not want to switch a GPO.

The event monitor names events defined under the ‘Protocol Assignment’ page in a particular way. It concatenates the channel number with the protocol event name. Thus, if there is a “Transition” control event for channel 1, the list of ON/OFF function names includes a “CH_1_Transition” entry.

- ▲ You may ignore the few “RESTORE_” event types.

Editing

Click ‘Edit’ above or below the table to edit one or more rows of the event table.

GPI

The tally processor's GPI option presents a table of 32 GPIs (inputs):

- Momentary GPIs will not detect OFF state change.
- For normal operation use Latched GPIs.

[Edit / Backup / Restore / Create Default / GPI Configuration Table](#)

GPI CONFIGURATION TABLE Refresh						
GPI#	Label	Opto Isolator State	GPI CURRENT EVENT STATE	Configuration		
				User Defined "ON" State	User Defined "ON" Mode	Debounce (*10 ms)
1	GPI_1	Energized	ON	OPTO ON	Latched	1
2	GPI_2	Deenergized	OFF	OPTO ON	Latched	1
3	GPI_3	Deenergized	OFF	OPTO ON	Latched	1
4	GPI_4	Deenergized	OFF	OPTO ON	Latched	1
5	GPI_5	Deenergized	OFF	OPTO ON	Latched	1
6	GPI_6	Deenergized	OFF	OPTO ON	Latched	1
7	GPI_7	Deenergized	OFF	OPTO ON	Momentary	1
8	GPI_8	Deenergized	OFF	OPTO ON	Latched	1
9	GPI_9	Deenergized	OFF	OPTO ON	Latched	1

You cannot add or delete inputs, but you can edit them. The other options at the top of the page include:

- Backup** Save your GPI configuration to a file (on your PC).
- Restore** Retrieve the GPI configuration from a saved file.
- Create Default** Reinitializes the Tally Processor's GPIs to a default configuration. (You'll get a warning "Are you sure")

Edit options

- ON State** 'OPTO ON' means that the switch is considered "on" when it is energized. 'OPTO OFF' means "on" when it is de-energized.
- Mode** Switching options are *latched* and *momentary*. Normal GPIs are latched GPIs.
Latched inputs remain ON until the actual inputs are switched off. Latched inputs follow the source signal.
Use *momentary* inputs for signals that are pulses.
- Debounce** Debounce options are expressed in multiples of 10 ms. A "1" means 10 ms; a "2" means 20 ms, and so on. A 0 value is not allowed.
Debounce filters unwanted signals. If the debounce time is longer than the input signal, the tally processor will ignore the signal.
Debounce is relevant only for momentary inputs. The maximum debounce value is 255 (2550 ms).
According to DNF, a latched input ignores its debounce value.

The 'Opto Isolator State' column tells you the actual state of the inputs (at the time of sampling).
The 'Current Event State' column tells you the logical state of the inputs (at the time of sampling).
You must click the 'Refresh' button to resample the inputs in the configuration tool.

1. Tally Processor

Using the Configuration Tool

GPO

The tally processor's GPO option presents a table of 32 GPIOs (outputs):

[Edit](#) / [Backup](#) / [Restore](#) / [Create Default](#) / GPO Configuration Table

GPO CONFIGURATION TABLE								Refresh
GPO#	Label	Current State	User Defined "ON" State	User Defined "ON" Mode	On time (*10 ms)	Transition Delay (*10 ms)	Debounce Time (*16 ms)	
1	GPO_1	ON	Relay Closed	Latched	1	0	1	
2	GPO_2	OFF	Relay Closed	Latched	1	0	1	
3	GPO_3	OFF	Relay Open	Latched	1	0	1	
4	GPO_4	OFF	Relay Closed	Latched	1	0	1	
5	GPO_5	OFF	Relay Closed	Latched	1	0	1	
6	GPO_6	OFF	Relay Closed	Latched	1	0	1	
7	GPO_7	OFF	Relay Closed	Momentary	1	0	1	
8	GPO_8	OFF	Relay Closed	Latched	1	0	1	
9	GPO_9	OFF	Relay Closed	Latched	1	0	1	
10	GPO_10	OFF	Relay Closed	Latched	1	0	1	
11	GPO_11	OFF	Relay Closed	Latched	1	0	1	
12	GPO_12	ON	Relay Open	Latched	1	0	1	
13	GPO_13	OFF	Relay Closed	Latched	1	0	1	
14	GPO_14	OFF	Relay Closed	Latched	1	0	1	

You cannot add or delete outputs, but you can edit them. The other options at the top of the page include:

- Backup** Save your GPO configuration to a file (on your PC).
- Restore** Retrieve the GPO configuration from a saved file.
- Create Default** Reinitializes the Tally Processor's GPOs to a default configuration. (You'll get a warning "Are you sure")

Edit options

- ON State** 'Relay Closed' means that the output state is considered "on" when NO and COM are connected. 'Relay Open' means that it is "on" when NO and COM are *not* connected. (There is no NC position.)
See [Connectors](#) on page 19 for the connector pinouts.
- Mode** Switching options are *latched* and *momentary*. Normal GPOs are latched. A momentary GPO produces a pulse. A 100ms pulse is generally suitable for performing VTR control.
- On Time** "On time" applies to momentary GPOs and is expressed in multiples of 10ms.
- Transition Delay** The amount of time from the triggering event to the change of the relay state. The transition delay is expressed in multiples of 10ms.
- Debounce** Debounce options are expressed in multiples of 16ms (not 10ms). A "1" means 10ms; a "2" means 20ms, and so on.

The 'Current State' column tells you the logical state of the outputs (at the time of sampling).

You must click the 'Refresh' button to resample the outputs.

The maximum for any of the time fields is 255.

Combinational Events

The ‘Combinational Events’ option presents a table of customer-defined logic statements:

- Create complex event definitions. Use local & remote GPIs & events.
- Event Label must be unique on this unit. Maximum of 15 characters.
- Definition example: GPI_1 AND GPI_2 OR GPI_3.

[Add](#) / [Edit](#) / [Delete](#) / [Backup](#) / [Restore](#) Combinatorial Event Definition

COMBINATORIAL EVENT DEFINITION TABLE		
Event Label	Combinatorial Event Definition	Enabled?
Start_1	CH_1_Preset_XPT_1 AND CH_1_Transition	YES
Start_2	CH_1_Preset_XPT_2 AND CH_1_Transition	YES
Start_3	CH_1_Preset_XPT_3 AND CH_1_Transition	YES
Start_4	CH_1_Preset_XPT_4 AND CH_1_Transition	YES
Start_5	CH_1_Preset_XPT_5 AND CH_1_Transition	YES
Start_6	CH_1_Preset_XPT_6 AND CH_1_Transition	YES
Start_7	CH_1_Preset_XPT_7 AND CH_1_Transition	YES
Start_8	CH_1_Preset_XPT_8 AND CH_1_Transition	YES

Refresh

[Add](#) / [Edit](#) / [Delete](#) / [Backup](#) / [Restore](#) Combinatorial Event Definition

You *can* add and delete events, and you can edit them. The other options at the top of the page include:

- Backup Save your GPO configuration to a file (on your PC).
- Restore Retrieve the GPO configuration from a saved file.

Combinational events are Boolean expressions involving “local events.”

Remote events that have a local ID may be included in the expressions. Use the ‘Remote Events’ option to identify remote events. (Remote events are those defined in another tally processor.)

Adding

When you add an event to this table, the event label must be unique, locally, i.e., on this tally processor.

1. Tally Processor

Using the Configuration Tool

The 'Add' dialog lets you build an expression using drop-down menus of event definitions and Boolean operators:

- Create combinatorial event definition using local events.
- For remote events, first create source event definition.
- Event Label must be unique on this unit.
- Event Label must contain only letters, numbers, and underscores.
- Event Label can must be 15 characters or less.
- Definition example: GPI_1 AND (GPI_2 OR GPI_3).
- Use Available Source Events and Operators drop down menu to append to Combinatorial Event Definition, OR manually enter source events, operators, and parenthesis.
- Equation cannot exceed 199 characters.

Add Combinatorial Source Definition

Event Label	<input type="text"/>
Available Source Events	Select one ...
Operators	Select one ...
Combinatorial Event Definition	<input type="text"/>
Enabled?	YES

Allowable operators are AND, OR, NOT, XOR, and NAND. Expressions use normal operator precedence. You can parenthesize any expression. You can also type directly in the 'Event Definition' field.

The sample expression given on the configuration page is

GPI_1 AND (GPI_2 OR GPI_3)

Normally, OR has lower precedence than AND. Placing the OR terms in parentheses causes the OR to be evaluated first.

Precedence

1 NOT

2 AND, NAND

3 OR, XOR (There is no NOR.)

The drop-down source list includes GPIs, GPOs, other previously defined combinatorial events, remote events, and master control events.

▲ An expression must have 199 characters or fewer.

Editing

You can edit textually any or all combinatorial events you have defined.

Remote Events

Remote events are those that occur in a separate tally processor. The tally processor you are configuring can recognize remote events. You can use a remote event as a source in a combinational expression or as an event to monitor. (See [Event Monitoring](#) on page 9).

The ‘Remote Events’ option assigns local labels to remote events:

- Create simple event definitions. Not required for local or remote GPIs.
- Event Definition Label must be unique on this unit. Maximum of 15 characters.

[Add / Edit / Delete / Backup / Restore](#) Remote Event Definition

REMOTE EVENT DEFINITION TABLE				
Local Event Label	Remote Event Label	Remote IP	Enabled ?	Connected ?
L1	R1	192.168.102.84	YES	NO

[Add / Edit / Delete / Backup / Restore](#) Remote Event Definition

When you add a remote event, the dialog is simple:

- Create event definitions for remote events. Not required for local GPIs.
- Event Definition Label must be unique on this unit and a maximum of 15 characters.
- Enter Local Event Definition Label, Remote Label, and Remote IP.

REMOTE EVENT DEFINITION TABLE			
Local Event Label	Remote Event Label	Remote IP	Enabled
<input type="text"/>	<input type="text"/>	<input type="text"/>	YES ▾

The ‘Remote IP’ field is for the IP address of the remote tally processor. The ‘Remote Event Label’ must have been defined in that tally processor.

1. Tally Processor

Using the Configuration Tool

2. Misc.

Chapter 2 provides miscellaneous information about tally processor. It presents the following topics:

- [PC Configuration](#)
- [Connectors](#)
- [Notes](#)

PC Configuration

You (or your system administrator) must connect the PC on which your software runs to the master control network. To do that, you must assign the PC an IP address (and mask) on the NIC that connects the PC to the master control network. (The PC must also be connected to the Ethernet switch of the network.)

Follow these steps to set the IP address of your PC:

- 1 Launch 'Settings>Network Configuration' from you PC's Start menu. The following window appears:

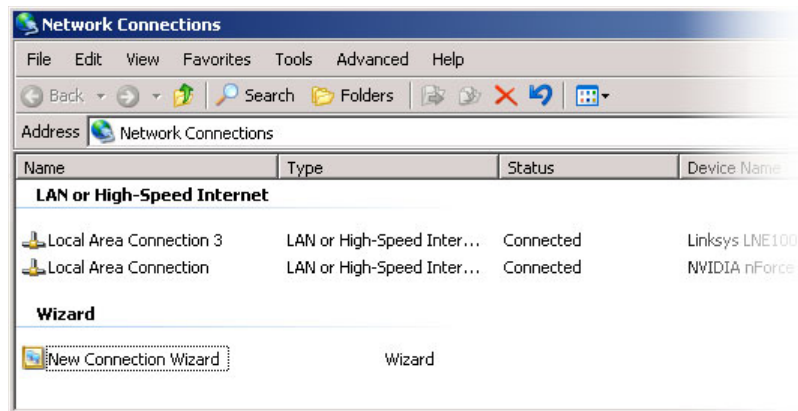

2. Misc.

PC Configuration

- 2 Double-click the appropriate 'Local Area Connection' for your master control network. Then, choose the General tab and click 'Properties'.

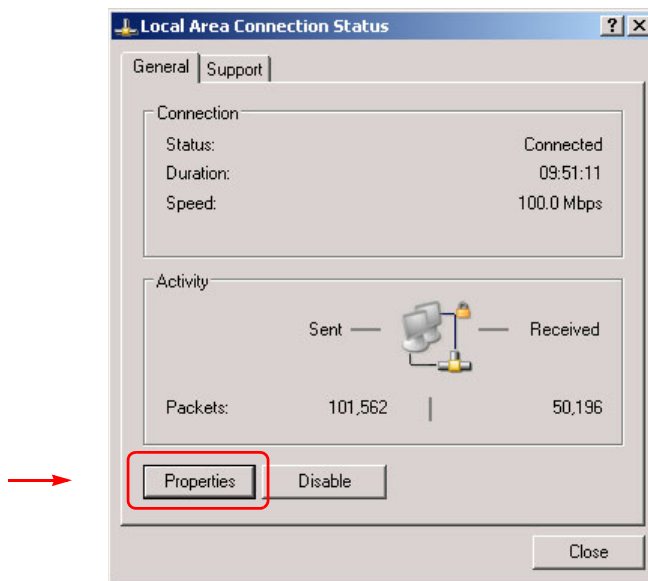

- 3 Select Internet Protocol (TCP/IP). Click 'Properties' again here:

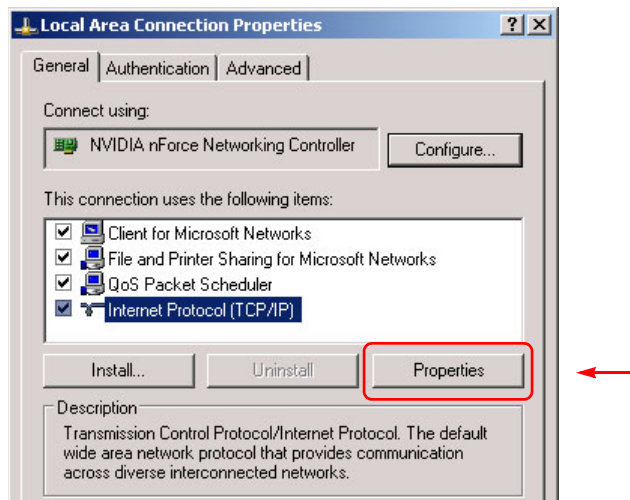

- 4 Select 'Use the following IP address' and enter an IP address for your PC. Use the default subnet mask.

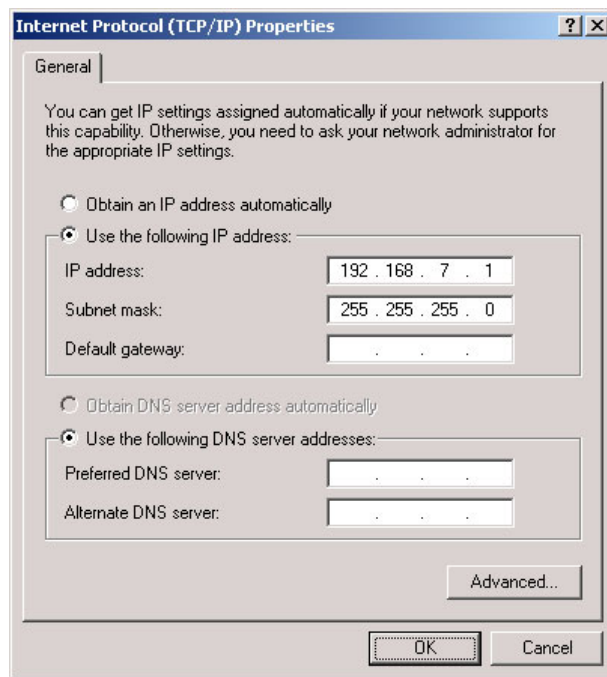

The IP address must be unique on the network. (The subnet mask must be 255.255.255.0.)

- 5 Click OK and it is done. Close all the Network Connections windows.

Connectors

GPIO

There are two GPI connectors (inputs 1–16 and inputs 17–32) and there are two GPO connectors (outputs 1–16 and outputs 17–32). These illustrations show the pin-out:

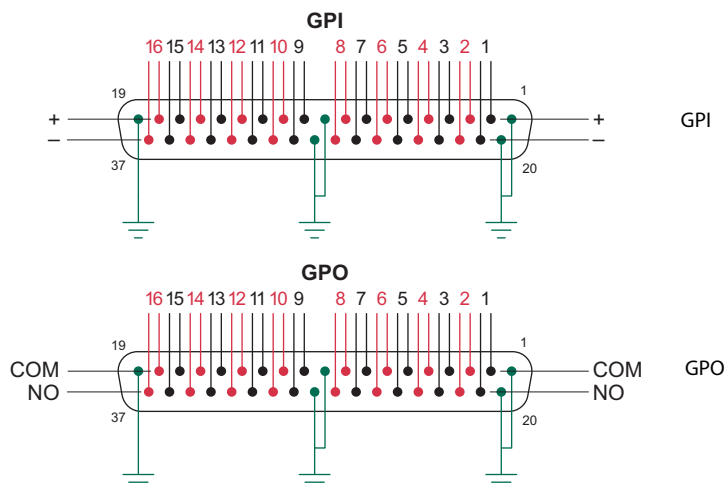

The input and output ranges 17–32 follow the same pattern.

2. Misc.

Notes

GPI limits:

5 VDC–12 VDC (or 24 VDC with a resistor of 680 to 820 ohms).
20 mA maximum current.

GPO limits:

0.5 A at 125 VAC.
1.0 A at 24 VDC.
1.0 A maximum current.

Power

The tally processor's power connector is a DE9 to which you normally connect the product's external power supply. In case you need it, this is the pinout of the power connector:

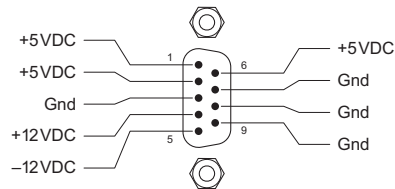

Notes

Although there are 2 Ethernet ports, only one—“E-net #1”—is usable.

General

To commit changes to the tally processor, you'll usually want to click a 'Save' button or similar function.

‘Save & Edit’ —save added entry and go back to the table.

‘Save & Add’ —save added entry and remain in the add box to continue to add.

Sometimes changes you make are accepted without your explicitly saving anything.

You can often cancel a change by clicking a 'Cancel' or 'Back' button.

Heed all warnings.

Saved Files

Although you are well-advised to save your configuration files, restoring configuration files can take a while. You shouldn't assume a restore has failed—do not interrupt the restore!

Under System Menu

Do not place the tally processor in router emulation mode.

‘VTR Control’ under the ‘System’ menu is unsupported.



Index

A

Adding events	10
Address	
mailing	iii
shipping	iii
Address, IP	17, 19
Arrow buttons	2-3

B

Back button	20
Boolean expressions	13
Button pad	2-3

C

Cancel button	20
CE declaration	ii
Channels	6
Chapters	
1, Introduction	1
2, Misc.	17
Combinational events (page)	4, 13
Combinational logic	9, 14
Configuration application	1, 3-4
Configuration PC	17
Configuration tables	4
Connectors	2, 19
Contact information	
technical support	iii
Control events	6
Copyright notice	ii
Current IP1	3
Current Mask1	3

D

DC37 connectors	2-3
DE9 connector	2
Debounce	11-12
Declaration of conformance (CE)	ii
Default password	5

Default user ID	5
DNF Controls	1
Document	
part number	ii
revision	ii

E

Email address	
tech support	iii
Enter button	2-3
Esc button	3
Ethernet connectors	2
Event definitions	6
Event functions	9
Event list	1, 3
Event monitoring (page)	4, 9
Events, adding	10
Events, master control	1

F

FCC statement	ii
---------------	----

G

GPI (page)	4, 11
GPI connectors	19
GPI mode	11
GPI state	11
GPO (page)	4, 12
GPO connectors	19
GPO mode	12
GPO state	12
GTP-32	1

I

Inputs, optically isolated	1
Internet Protocol (TCP/IP)	18
Introduction	1

Index

IP address 2–3, 10, 17, 19
IP subnet mask 3

L

Latched (option) 11–12
LCD, 2×16 2–3
LEDs 2
Local Area Connection 18
Local events 10

M

Mailing address iii
Master control events 1, 6, 9–10
MCEs 1–2, 4, 6–7
MCPMs 1–2, 4, 6–7
Miranda
 email, tech support iii
 mailing address iii
 main number iii
 sales number iii
 shipping address iii
 technical support iii
 website address iii
Momentary (option) 11–12
Monitor events 7

N

Network Configuration 17
Network Connections 19
Notes 20
NVEP 1, 6, 10
NVISION Ethernet protocol
 see NVEP

O

On time 12
Outputs, relay 1

P

Part number, document ii
PC Configuration 17
PHY Config 6
Power supply 2
Protocol assignment (page) 4, 6

R

Refresh button 11–12
Relational operators 7
Relay outputs 1
Remote events 10
Remote events (page) 4, 15
Repetitive (option) 9–10
Return Material Authorization (RMA) iii
Revision
 document ii
RJ-45 connectors 2
RMA iii

S

Sales number iii
Save & add button 20
Save & edit button 20
Settings, Windows 17
Shipping address iii
Single (option) 9–10
Software version ii
Sub-pages, configuration application 4
System (page) 4, 20
System option 3

T

Tables 4, 9
Technical support iii
Telephone number
 main iii
 sales iii
 technical support iii
Time-out 5
Trademarks iii
Transition delay 12

V

Version, software ii

W

Website, Miranda iii
Windows, settings 17